

DATA SHEET

# BELL GAUSSMETER

## Model 5200 series

BELL 5270/5280 GAUSSMETER/  
TESLAMETER



### 01 Description

The 5200 series Hall effect portable gaussmeters represent the most recent design from the world leader in magnetic measuring equipment. This design incorporates the use of digital signal processing technology. F.W. Bell's exclusive dynamic probe correction allows measurements from 0 to 30 kG with a basic accuracy of 1%.

Key features include auto zero, min./max./peak hold, auto range and relative mode. Both models allow the user to select Gauss, Tesla or Ampere/meter readings. Both 5280 & 5270 features a corrected analog output ( $\pm 3V$  FS) and a USB communication port.

The 5200 series hand-held gaussmeter's built-in software eliminates the need for complex calibration procedures. User prompts on the custom formatted LCD allow fast, simple push button and touch operations. All models come equipped with a detachable transverse probe, zero gauss chamber, instruction manual, hard carrying case, and a Li-Ion rechargeable battery. Axial, ultra-thin transverse and low-field probes are available as options.

#### Probe Options

5270	5280
STH17-0404, 4" transverse	STD18-0404, 4" transverse
STH17-0402, 2" transverse	STD18-0402, 2" transverse
SAH17-1904, 4" axial	SAD18-1904, 4" axial
SAH17-1902, 2" axial	SAD18-1902, 2" axial
HTH17-0604, 4" transverse	HTD18-0604, 4" transverse
STB1X-0201, ultra-thin, transverse	
MOS51-3204, low field	

### 02 Key features and benefits

- 4.3" LCD touch-screen
- Controls for sound/brightness/dark mode
- 10 to 14 hours on Li-Ion rechargeable battery
- 2 hours charge time typically
- USB-C 2.0
- Remote PC control option
- 512 kBit internal memory (5280)
- Audio/visual alert when in range (5280)
- CE compliant

### 03 Applications

- Sensitive laboratory environment
- Rugged industrial setting
- Magnetic field intensity verification
- Measurement of magnetic componets/motors
- North/South polarity
- Magnetic field leakage detection



## DATA SHEET

# GAUSSMETER, Model 5200 Series

## 05 Specifications

Characteristics		
Model:	5270	5280
Basic DC accuracy	2%	1.1%
Frequency bandwidth	DC-20 kHz	DC-25 kHz
Update rate:		
Display	10 updates / sec.	10 updates / sec.
Analog	100K samples / sec.	100K samples / sec.
Ranges:		
Ultra-low range	1 G	1 G
Low range	200 G	300 G
Mid-range	2 kG	3 kG
High range	20 kG	30 kG
Resolution:		
Ultra-low range	1 mG	1 mG
Low range	0.1 G	0.1 G
Mid-range	1 G	1 G
High range	10 G	10 G
Readings	Gauss, Tesla, Amps/meter	Gauss, Tesla, Amps/meter
Operating temperature	0°C to 50°C	
Storage temperature	-25°C to 70°C	
Meter weight	0.98 lbs. (443 g)	
Size	8.00" x 3.85" x 1.87" (20.32 cm x 9.78 x 4.75 cm)	
Compliance	EN IEC 61326-1:2021	
Drop Test	1 Meter drop per IEC 61010-1: 2010	

## 06 Outline details

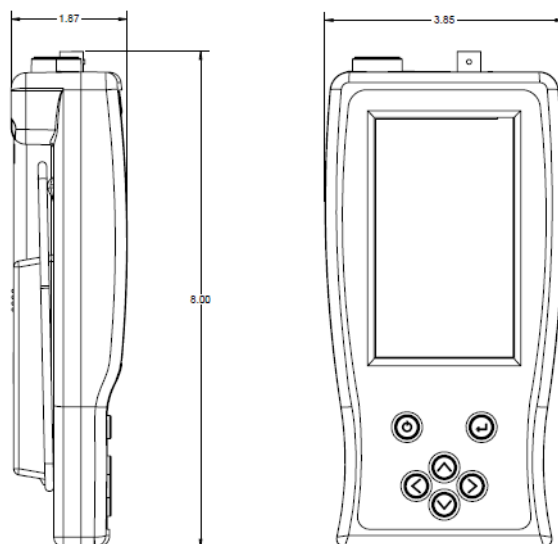

Note: Due to continuous process improvement, specifications are subject to change without notice.



SHANGHAI TIANCHUN TECHNOLOGY CO.,LTD  
Tel:86-21-69950169 138-1704-5024  
Email: sales@imeter.com.cn Http://www.testmeter.com.cn